



HEATERS



SM



AXIAL HEATERS

Brock's GUARDIAN® Series Axial Heaters are available in 24-, 26-, and 28-inch (610-, 660-, and 711-mm) diameters to match your grain conditioning needs. Low temperature heaters are also available.

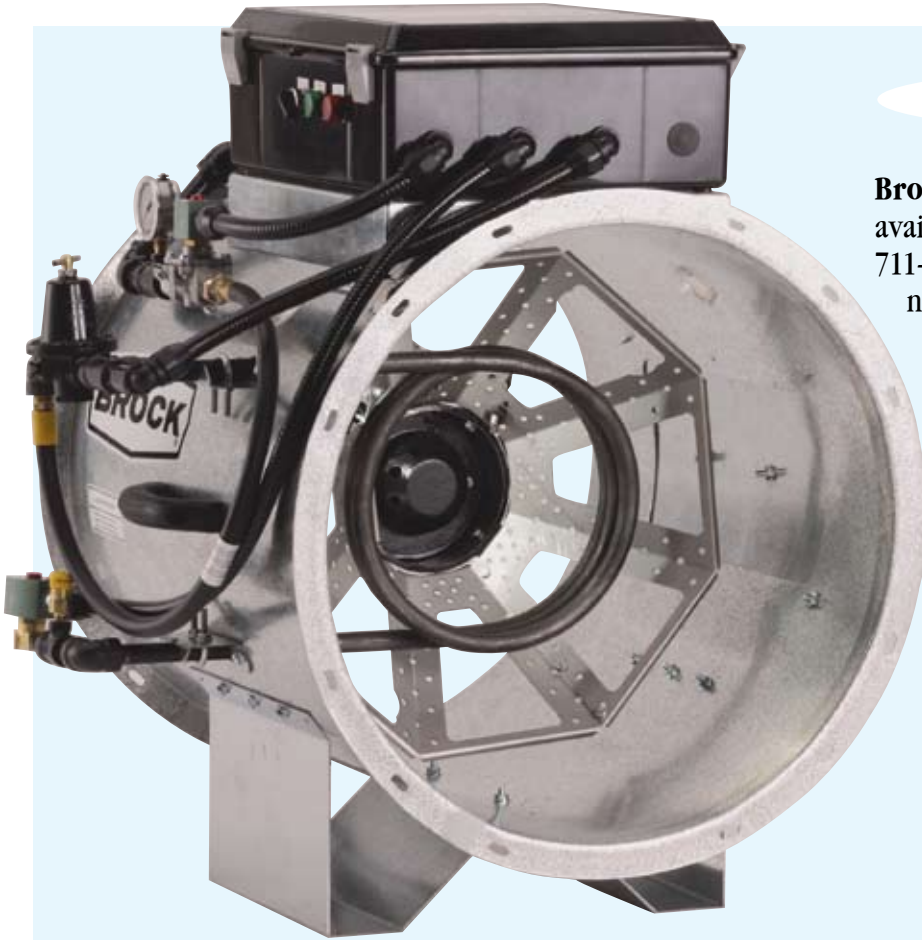

Heater models are available for use with liquid propane, propane vapor, or natural gas fuels and utilize gas-certified solenoid valves. Brock-supplied regulators are standard on liquid propane models.

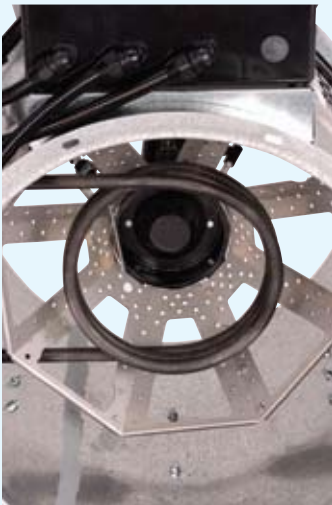

Liquid propane heater models include a **high-capacity internal vaporizer**. Stainless steel **cone** is standard.



Rodent-resistant conduit protects all exposed wiring, including ignition and flame circuit wires in the burner unit.



Brock's heaters feature a large **service access door**. Convenient **sight ports** on both sides of the heater unit make it easy to do visual checks on the burner unit.

CENTRIFUGAL DOWNSTREAM HEATERS

Brock's GUARDIAN® Series Centrifugal Downstream Heaters are available to match centrifugal fan models and offer BTU capacities of up to 5,000,000. This gives you the flexibility required to meet your grain conditioning needs for in-bin drying.



Heater models are available for use with liquid propane, propane vapor, or natural gas fuels and utilize gas-certified solenoid valves. Brock-supplied regulators are standard on liquid propane models.

Brock's full flame-wall burner provides top fuel-saving performance along with even heat distribution. This design is the most efficient style of burner available. Stainless steel baffles are standard.



Liquid propane heater models include a high-capacity internal vaporizer. Vaporizer design features built-in flexibility to position the unit's coil for optimum performance.



Large inspection door provides maximum accessibility to make it easy to service burner and vaporizer unit. Convenient sight ports on both sides of the heater make it easy to do visual checks on burner unit operation.



Rodent-resistant conduit protects all exposed wiring, including ignition and flame circuit wires in the burner unit.

SPECIFIC CONTROLS, STANDARD BOX



Brock's GUARDIAN® Series controls are specifically matched to each heater unit and feature industrial-grade water-tight switches and lights.

Made of durable polycarbonate material with a hinged translucent cover, the **control housing** is resistant to weather, dust and rodents.



Brock's heater controls use an industrial-design **ignition transformer**. **Terminal blocks** are provided for easy connection of external controls.

All Brock GUARDIAN Series Heaters incorporate a reliable **industrial flame rectification system**.

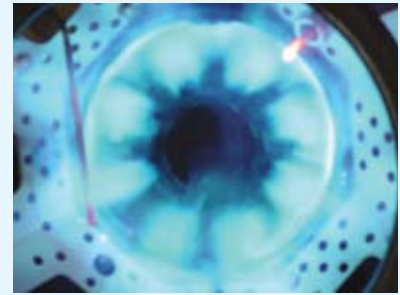

HEATER RATINGS

SPECIFICATIONS:

Axial Heaters

Heater Model	Fuel Type	Capacity Range (BTU)
AX24-N/PV	Natural Gas/Propane Vapor	800,000 - 2,200,000
AX24-N/PV-LT	Natural Gas/Propane Vapor	250,000 - 750,000
AX24-LP	Liquid Propane	800,000 - 2,200,000
AX26-N/PV	Natural Gas/Propane Vapor	1,000,000 - 2,600,000
AX26-N/PV-LT	Natural Gas/Propane Vapor	300,000 - 750,000
AX26-LP	Liquid Propane	1,000,000 - 2,600,000
AX28-N/PV	Natural Gas/Propane Vapor	1,100,000 - 3,000,000
AX28-N/PV-LT	Natural Gas/Propane Vapor	350,000 - 1,100,000
AX28-LP	Liquid Propane	1,100,000 - 3,000,000

Centrifugal Downstream Heaters

Heater Model	Fuel Type	Capacity Range (BTU)
CDH2710-N/PV	Natural Gas/Propane Vapor	1,200,000 - 2,100,000
CDH2710-LP	Liquid Propane	1,200,000 - 2,100,000
CDH2715-N/PV	Natural Gas/Propane Vapor	1,600,000 - 2,800,000
CDH2715-LP	Liquid Propane	1,600,000 - 2,800,000
CDH2720-N/PV	Natural Gas/Propane Vapor	1,750,000 - 3,100,000
CDH2720-LP	Liquid Propane	1,750,000 - 3,100,000
CDH30-25,30-N/PV	Natural Gas/Propane Vapor	2,300,000 - 4,000,000
CDH30-25,30-LP	Liquid Propane	2,300,000 - 4,000,000
CDH33-40,50-N/PV	Natural Gas/Propane Vapor	3,000,000 - 5,000,000
CDH33-40,50-LP	Liquid Propane	3,000,000 - 5,000,000



Brock Grain Systems
Chore-Time Brock International
 Divisions of CTB, Inc.

Milford, IN • Kansas City, MO • Frankfort, IN
 Phone: 574.658.4191 or +1.574.658.9323 (International)
 Internet: www.brockgrain.com or www.ctbworld.com
 E-Mail: brock@brockgrain.com