



**Rotary
Products inc.**

202 East High Street P.O. Box 370
Ashley, OH 43003
1-800-457-5251 Phone: (740) 747-2623
Fax: (740) 747-2188

INSTALLATION INSTRUCTIONS FOR COMPRESSION SEALS

Your Rotary Products Compression Seal has been custom manufactured for your installation, based on the dock survey information supplied to the factory.

Your Compression Seal is:

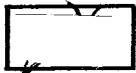

Standard Compression Seal
(for door openings less than 9' wide)



Z Series "Superwedge"
(for door openings 9' to 10' wide)

It has a:

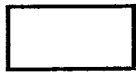

Regular Header



Regular Header w/Curtain Option
(curtain sewn onto header)

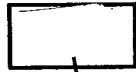

MC Curtain Header



Adjustable Curtain Header

PARTS LIST:

Right Vertical, Left Vertical
(Vent pockets on verticals are ALWAYS on outside of vertical and open toward the ground)

Header

Contents of Hardware Box:

Instruction Sheet
9 Angle Brackets for Outside of Seal
9 Flat or Angle Brackets for Inside of Seal
5/16" Lag Screws to attach brackets to Compression Seal

Backing Board (installer must provide fasteners to anchor Compression Seal to building.)

FOR MC CURTAIN HEADER ONLY:

2 5/16" lag screws and washers for tie-down straps

FOR ADJUSTABLE CURTAIN HEADER ONLY:

3 ropes rope cleat 2 wood screws

CHECK PACKAGES TO MAKE SURE ALL PARTS ARE ACCOUNTED FOR

ALL DIRECTIONS ARE GIVEN FACING BUILDING

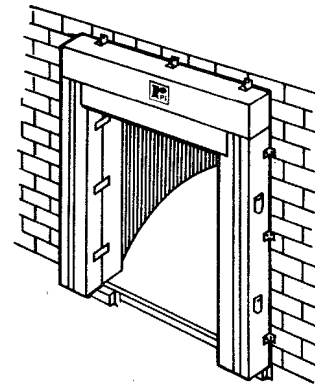

Standard
Compression
Seal

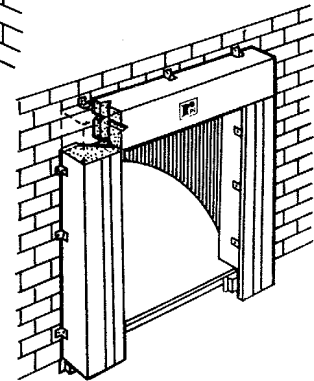

Z Series
"Superwedge"

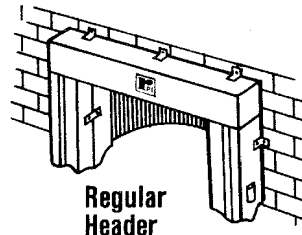

Regular
Header

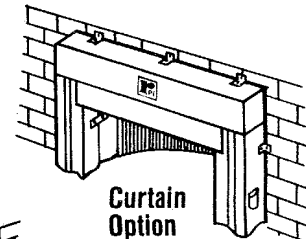

Curtain
Option

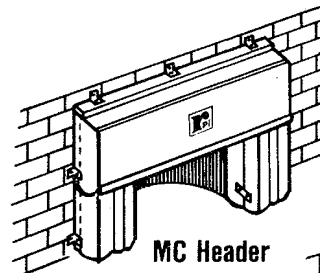

MC Header

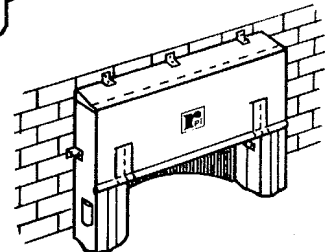

Adjustable Curtain Header

NOTE: IN ALL COMPRESSION SEAL INSTALLATIONS

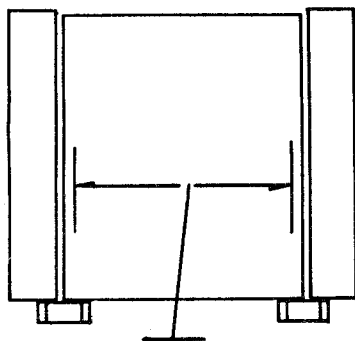

Make sure all verticals are parallel to door opening.

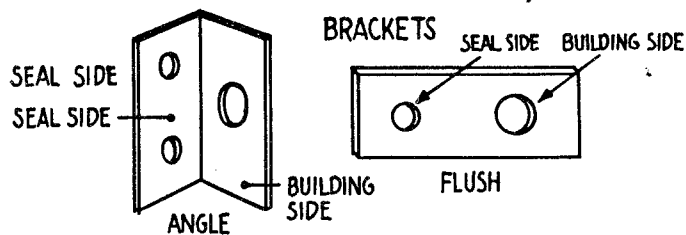

The seal side of the bracket is the one with the small holes, use lag screws provided to attach to Compression Seal Backing Board.

The building side of the bracket is the one with large holes, installer must provide fastener to securely anchor the Compression Seal to the building. The brackets must be positioned so they anchor to firm support either on Door Frame or Building Wall.

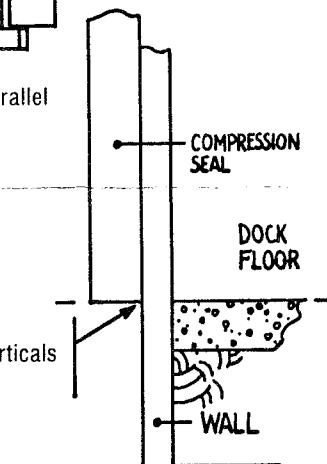

Make sure bottom of both verticals are even with the dock floor.

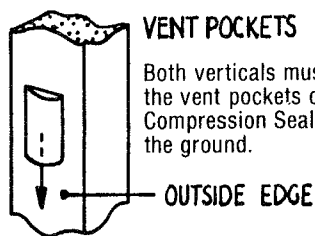

Both verticals must be positioned with the vent pockets on outside of the Compression Seal and opening toward the ground.

OUTSIDE-TO-OUTSIDE MEASUREMENT SHOULD BE THE SAME AS THE LENGTH OF YOUR HEADER.

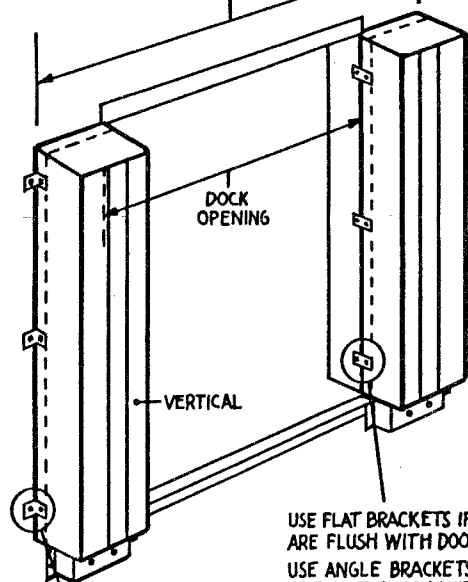

USE FLAT BRACKETS IF VERTICALS ARE FLUSH WITH DOOR OPENING.
USE ANGLE BRACKETS IF VERTICALS ARE NOT FLUSH WITH DOOR OPENING.

USE ANGLE BRACKETS ON OUTSIDE.
(6 REQUIRED FOR VERTICALS)

STANDARD COMPRESSION SEAL

1. Secure the verticals to the wall, using brackets provided. The verticals should measure the same distance outside-to-outside as the length of the header. Make sure the verticals are plumb at both top and bottom. The bottom of the verticals should be exactly at dock floor level. **BE SURE THE VENT POCKETS ARE ON THE OUTSIDE OF THE VERTICALS WITH THE OPEN END TOWARD THE GROUND.**

2. Use 6 angle brackets on outside of the verticals (three on each vertical) and 6 flat or angle brackets on inside (three on each vertical.) The Compression Seal side of the bracket is the one with the small hole, and the building side of the bracket is the one with the large hole. The Compression Seal side should be attached to backing board with lag screws provided. The installer must provide fastener to securely anchor Compression Seal to the building. **POSITION THE BRACKETS SO THAT THEY ARE ANCHORED TO FIRM SUPPORT ON DOOR FRAME OR BUILDING WALL.**

3. To complete installation, see the instruction for the style of header provided with your compression seal.

Z SERIES "SUPERWEDGE" SEAL

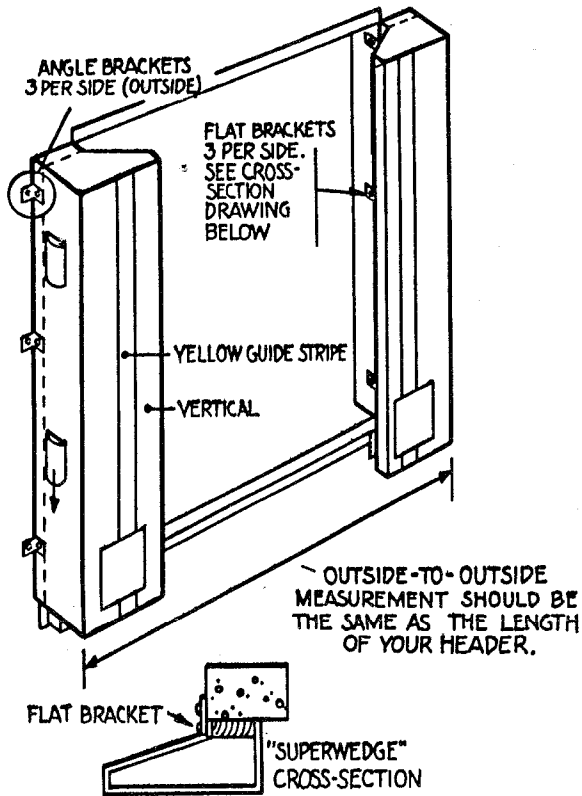

1. Secure the verticals to the wall, using brackets provided. The verticals should measure the same distance outside-to-outside as the length of the header. Make sure the verticals are plumb at both top and bottom. The bottom of the verticals should be exactly at dock floor level. BE SURE THE VENT POCKETS ARE ON THE OUTSIDE OF THE VERTICALS WITH THE OPEN END TOWARD THE GROUND.

2. Use 6 angle brackets on the outside of the verticals (three on each vertical) and 6 flat brackets on inside (three on each vertical.) The seal side of the bracket is the side with small holes, and the building side of the bracket is the one with the large hole. The Compression Seal side should be attached to the backing board with the lag screws provided. The installer must provide fasteners to securely anchor the Compression Seal to the building. POSITION THE BRACKETS SO THAT THEY ARE ANCHORED TO FIRM SUPPORT ON THE DOOR FRAME OR THE BUILDING WALL.

3. To complete installation, see instruction for the style of header provided with your "SUPERWEDGE" compression seal.

NOTE: INFORMATION ABOUT INSTALLATION OF COMPRESSION SEALS ON METAL BUILDINGS

1. When installing a compression seal on a metal building it is important that the mounting brackets be securely anchored to the frame of the building. It may be necessary to thru-bolt the outside brackets. If this is the case, it is recommended that you use 3/8" bolts.

2. The preferred method for mounting the outside brackets is to anchor them to the metal cross pieces that support the skin of the building. Generally, you will find only one or two cross pieces along the length of the vertical members. If there are two cross pieces, you will have two substantial places to mount brackets, this should be sufficient. If there is only one cross piece to work with, to anchor a second bracket it will be necessary to bolt through the metal skin of the building. Use as large a washer assembly as possible inside the skin of the building. It can also be helpful to put one of the angle brackets underneath the vertical, so that one leg of the angle bracket can be anchored to the concrete base of the building.

3. If the outside edge of the vertical falls on a low spot of an irregular metal surface, you can shim the gap between the vertical and the skin with 1 1/2" thick lumber.

4. Depending on the type of construction, the header of the compression seal may or may not pose some installation problems. The C-shaped channels of steel that make up the door frame of some metal buildings continue up the wall over the door. This type of framework will give you two solid members for anchoring the header sufficiently. On many newer buildings these frame channels only surround the door itself. In this case you will need to mount by bolting through the skin and using a washer assembly and wood spacers as mentioned above.

The factory has preformed closure material for the gaps at the top of the header, available at a small additional cost.

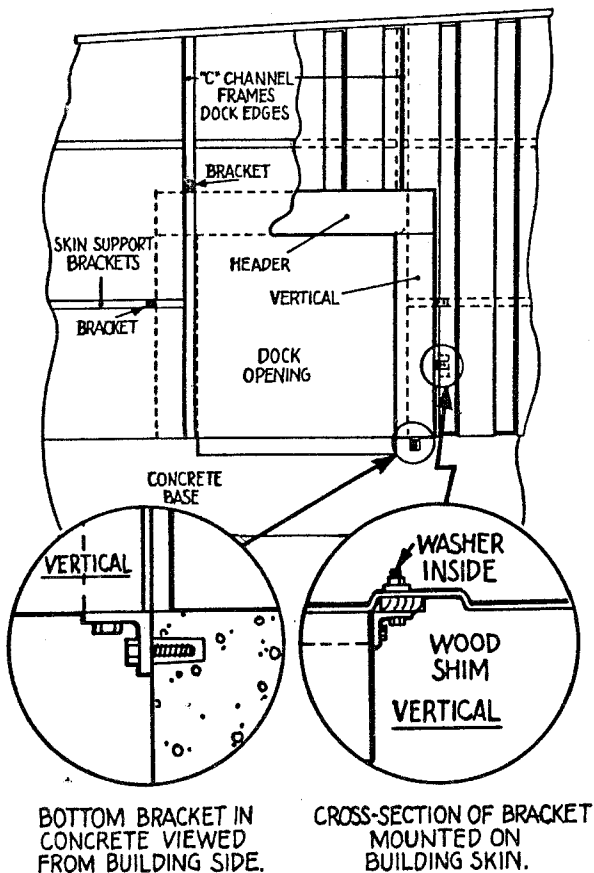

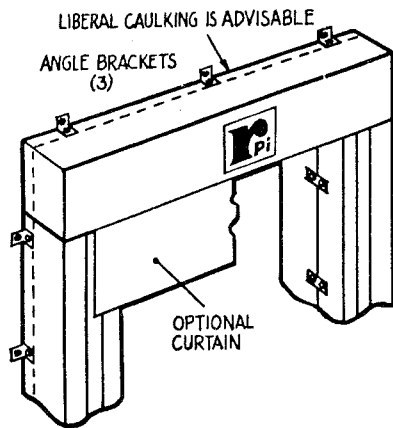

STANDARD HEADER (Curtain Optional)

1. Place header on top of verticals. Attach the header to wall with three angle brackets on outside of the header and three flat or angle brackets on inside of header.
2. Liberal caulking above the header is recommended.
3. *Curtain Option:* Curtain should hang down in front of the verticals. The curtain length is determined by the dock survey information supplied to the factory.

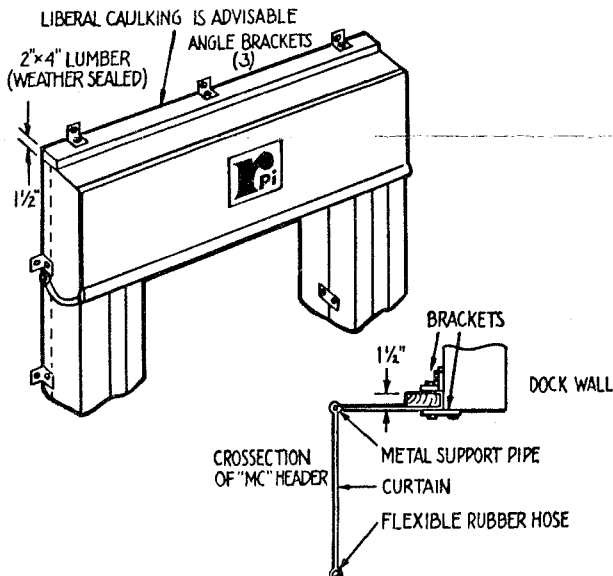

MC CURTAIN HEADER

1. Rest Curtain Header board on top of the verticals and against the wall of the building. The 1/2" side of the 2 x 4 should be against the wall.
2. Secure the header board to the building wall with brackets provided. Three angle brackets on outside of header and three flat/angle brackets on inside.
3. Bring the top of the header over the verticals so the metal support pipe is at the front of the verticals. Let the MC Curtain drop down in front of the verticals.
4. At each end of the curtain, the attached rubber tie-down straps should be taken straight back to the backing board and attached with lag screws and washers provided. The tie-down strap should have some slack in it to allow for movement of the header curtain.
5. Liberal caulking above the header is recommended.

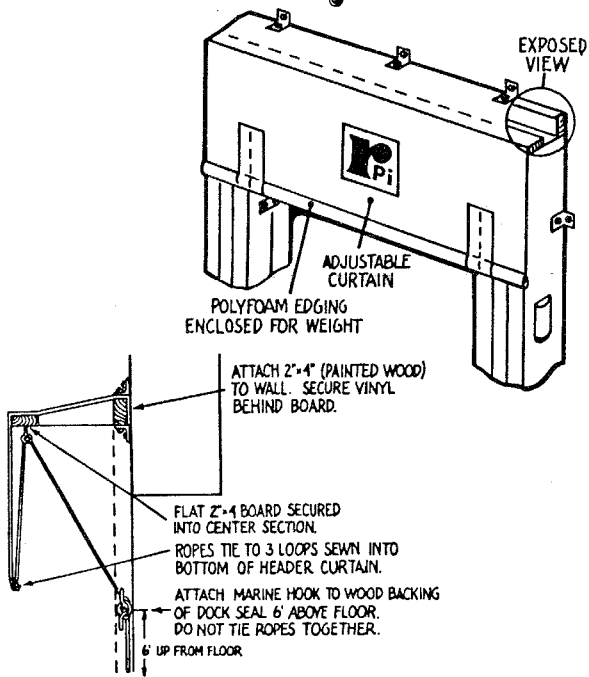

ADJUSTABLE CURTAIN HEADER

1. Place the adjustable curtain header on top of the verticals with the upright board (3 1/2" side of the 2 x 4) against the building, and the flat 2 x 4 board (with eye lag) at front of vertical.
2. Be sure vinyl is between board and building. Attach board to building wall with 6 angle brackets provided, three outside and three inside.
3. Let curtain drop down outside of the verticals. Attach ropes to loops sewn into bottom of the header curtain and thread ropes through eye lags to right side of curtain. NOTE: DO NOT TIE THE ROPES TOGETHER.
4. Attach rope cleat to the wood backing of the vertical, approximately 6' from dock floor.
5. Liberal caulking above the header is recommended.

Thank you for choosing a fine Rotary Products, Inc. Dock Seal. If you have any problems with installation or questions about the dock seals, call Chris at 1-800-457-5251.

