

REALiS
MULTIMEDIA PROJECTORS

Canon



WUX10 Mark II

WUX10 Mark II D

SX7

SX6

SX80 Mark II

SX80 Mark II D

SX60

SX800

X700

PRESENTING EXCELLENCE.
Rich Color. Deep Contrast. Sharp Resolution.



Canon: Focused on Leadership

LOOKING FOR EXCELLENCE IN PRESENTATION TECHNOLOGY? YOU'VE COME TO THE RIGHT SOURCE. FOR OVER

70 YEARS, CANON'S HERITAGE IN OPTICS AND COLOR MANAGEMENT REMAINS UNRIVALLED.

UNLIKE OTHER MANUFACTURERS, CANON'S MAIN

FOCUS IS THE OPTICAL SCIENCES. WE SPEND SIGNIFICANT R&D RESOURCES

IN CULTIVATING GROWTH IN THE FIVE "IMAGING ENGINES" – IMAGE CAPTURING, ELECTROPHOTOGRAPHY,

INKJET PRINTING, PHOTOLITHOGRAPHY AND DISPLAYS – AND THESE EXCITING

BREAKTHROUGHS BENEFIT EVERY CANON PRODUCT, INCLUDING, OF COURSE, CANON

REALiS PROJECTORS WITH LCOS (LIQUID CRYSTAL ON SILICON) TECHNOLOGY. FROM

THE CREATION OF THE INCOMPARABLE CANON LENS TO CANON'S HIGH-ACCURACY

COLOR MANAGEMENT SYSTEM, CANON OPTICS ARE BEST-OF-BREED.

THE IMAGE OF PERFECTION.



Canon

LCOS vs. LCD or DLP: What can REALiS do for you?

What's the LCOS technology advantage? Lattice-free, seamless images and smooth film-like quality video.

Say goodbye to annoying visual distractions common with LCD projectors, such as the grid-like pixel patterns known as "screen door effect." Compared to LCD panels, LCOS panels result in smaller gaps seen between pixels – virtually eliminating the screen door.

Single-chip DLP projectors can produce troublesome red-green-blue spots, frequently referred to as a "rainbow effect". LCOS panel technology does not have this problem inherent to single-chip DLP projectors.

The seamless images projected using LCOS panels result in images with realistic depth and intricate detail. Fine lines are displayed accurately and clearly. Small text is crisp and dark (even at 7pt.), making it easy to read. Thanks to the fast response time of LCOS panels, high definition video leaps off the screen with breathtaking quality and integrity.

There's no comparison. The advantages of LCOS are easy to see for both presenter and audience alike: crisp, clean images with deep contrast, fine grain and sharp resolution.

There's no clearer choice than REALiS.

Display of fine lines

CAD images, blueprints and fine lines are reproduced smoothly and accurately with REALiS high-resolution projectors.

3-panel LCOS



3-panel LCD



1-chip DLP

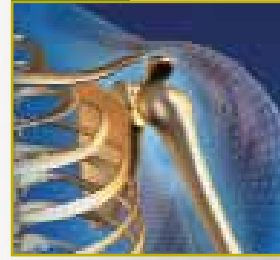

Display of color and detail

REALiS SXGA+ models present exceptional color and intricate detail.

3-panel LCOS



3-panel LCD



1-chip DLP



Display of small text

By using more pixels for each letter, REALiS projectors can display easy-to-read type, as small as 7pt., often illegible on LCD-based XGA projectors.

3-panel LCOS



3-panel LCD



1-chip DLP



Display of fine grained objects

REALiS lattice-free images ensure smooth, crisp displays of fine grained objects, including metallic surfaces, typically dulled by LCD projectors.

3-panel LCOS



3-panel LCD



1-chip DLP



Images shown are for illustration purposes only. Simulated images displayed based on differences in aperture ratio for projectors using LCOS (>90%), LCD (60%), and DLP (<90%).



OUR PIXELS ARE REALLY CLOSE

The AISYS Advantage

Taking LCOS to the Next Level

Rarely satisfied and never complacent, count on Canon – and only Canon – to develop a method for making LCOS technology even better. Our proprietary AISYS optical system

Image quality is optimized thanks to new optical elements that were incorporated into the illumination optical system, enhancing the uniformity of light. Technically speaking, the Polarizing Beam Splitters (PBS) in the color separation and recombination system are now designed for more precise light control. AISYS even allows us to produce a more compact unit, reducing unit weight and cost.

AISYS OPTICAL SYSTEM

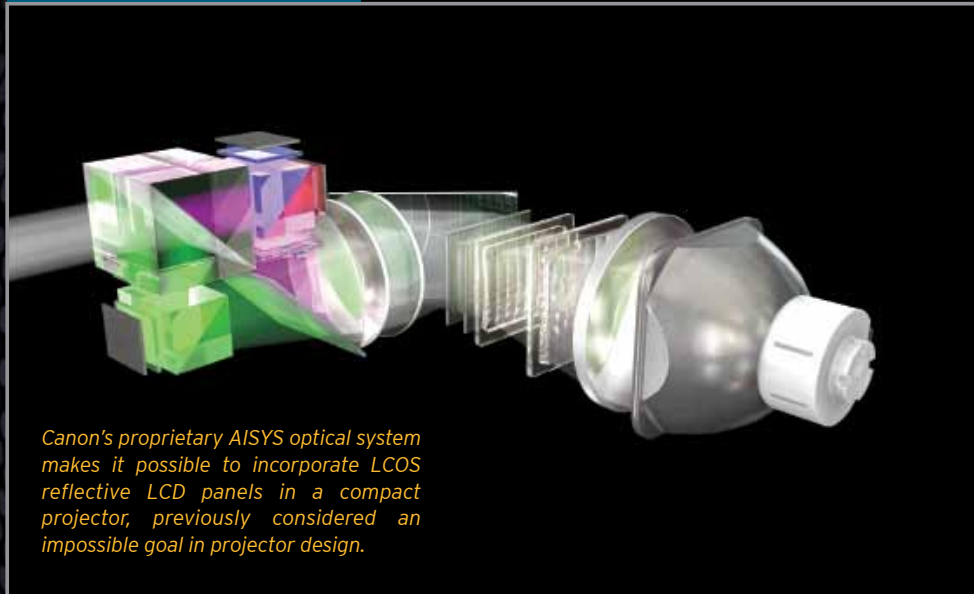

Canon's proprietary AISYS optical system makes it possible to incorporate LCOS reflective LCD panels in a compact projector, previously considered an impossible goal in projector design.

What does all this science mean to you? It means no one does LCOS like Canon. REALiS brings you a whole new standard in bright, beautiful, high-definition, high-contrast images. REALiS assures a captivated audience. REALiS assures confident presenters. REALiS brings you the next level in LCOS performance.

efficiently utilizes and equalizes light from the projector lamp, thereby boosting the performance of both key functions: brightness and contrast. AISYS, which stands for Aspectual Illumination System, increases brightness and contrast together; one function never sacrifices the other, and that's a capability only Canon can deliver.



OUR PIXELS ARE REALLY CLOSE

REALiS Multimedia Projectors come in a variety of models and feature sets to match your discerning needs. Select the solution that's right for you.

NEW!



WUX10 Mark II / WUX10 Mark II D High Definition

- 1.5x optical powered zoom lens
- Full 10-bit image processing
- HDMI™ V.1.3 Deep Color with 1080p Support
- Photo Image Mode
- DICOM Mode (WUX10 Mark II D only)

LCOS | WUXGA 1920 x 1200 | 3200 Lumens



SX7 Astounding Color Reproduction

- 1.7x optical powered zoom lens
- Adobe RGB color-match system
- 1000:1 contrast ratio

LCOS | SXGA+ 1400 x 1050 | 4000 Lumens



SX6 Exceptional Image Quality

- 1.7x optical powered zoom lens
- Adobe RGB color-match system
- 1000:1 contrast ratio

LCOS | SXGA+ 1400 x 1050 | 3500 Lumens

NEW!



SX80 Mark II / SX80 Mark II D Versatile Performance

- 1.5x optical powered zoom lens
- 900:1 contrast ratio
- HDMI™ V.1.3 Deep Color with 1080p Support
- Photo Image Mode
- PC-free presentation, PictBridge
- DICOM Mode (WUX10 Mark II D only)

LCOS | SXGA+ 1400 x 1050 | 3000 Lumens



SX60 Whisper-Quiet Operation

- 1.7x optical powered zoom lens
- 1000:1 contrast ratio
- 2000:1 contrast ratio in Home Cinema mode

LCOS | SXGA+ 1400 x 1050 | 2500 Lumens



SX800 Affordable and Reliable

- 1.5x optical powered zoom lens
- 900:1 contrast ratio

LCOS | SXGA+ 1400 x 1050 | 3000 Lumens



X700 High Quality - Fast, Easy and Quiet

- 1.7x optical powered zoom lens
- 1000:1 contrast ratio

LCOS | XGA 1024 x 768 | 4000 Lumens

Project an Enhanced Image

Whether you're in the engineering, architecture or business field...in healthcare, higher education or government...in fine arts, fashion or graphic design...if you're in the business of making impressions, impress your audience with REALiS.

Engineering, Architecture & Business

- The fine lines of blueprints and renderings are visible in clear detail.
- Contrast and accurate shadowing maximize form and texture.
- Tiny type is clearly readable and complex charts spring to life.

Healthcare, Higher Education & Government

- Anatomical imagery and microscopic photography are recreated true-to-life.
- Historical documents and photos display stunning resolution.
- Intricate charts, maps and grids are easily viewed from a distance.

Fine Arts, Fashion & Graphic Design

- Even the subtlest hues and color gradations are reproduced with amazing clarity.
- Crisp contrast and accurate grayscale help produce a true picture.
- Fine detail and razor resolution add depth, dimension and drama.

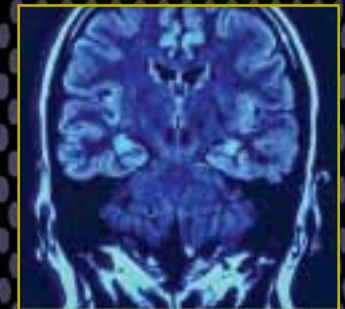

REALiS Simple. REALiS Spectacular.

SIMPLY PUT, OUR CANON REALiS MULTIMEDIA PROJECTOR LINEUP PROVIDES POWERFUL FEATURES AND LEADING PERFORMANCE THAT EXCEED THE MOST DEMANDING QUALITY EXPECTATIONS – AND WE DO SO ON AN ORDER OF MAGNITUDE FAR BEYOND OTHER SYSTEMS. YES, THERE ARE OTHER PROJECTORS AVAILABLE, BUT CANON SIMPLY DOES IT BEST.

Chart A

Genuine Canon Optics

In Canon's REALiS Series, the lens configuration is a six-group assembly with 12 elements and four moving groups, featuring one UD lens and two high-precision double-sided aspherical lenses. The result: amazing clarity.

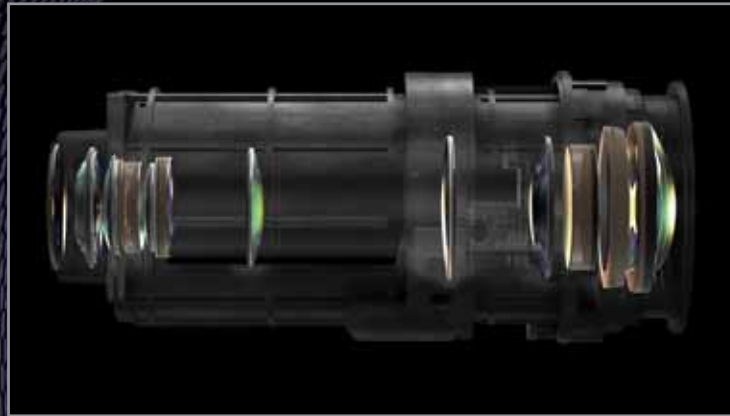

WUXGA Super-High Resolution

This exciting new technology means Canon now offers a WUXGA LCOS projector, featuring superior brightness, spectacular image quality and flexible operational functions – all in a conveniently compact and cost-effective package. In fact, the latest notebook PCs already support native WUXGA, an ideal solution for today's HD and Blu-Ray content. (See chart A)

WUX10 Mark II WUX10 Mark II D SX7 SX6
SX80 Mark II SX80 Mark II D SX60 SX800 X700

1.5x Power Zoom Lens

The new 1.5x Powered Zoom Lens has been engineered to accommodate LCOS reflective LCD panels. And, with our new 10:0 lens offset, REALiS projectors can now be pulled back even further without the image hitting the table or the ceiling. This minimizes the need for keystone correction. (See chart on opposite page.)

WUX10 Mark II WUX10 Mark II D SX7 SX6
SX80 Mark II SX80 Mark II D SX60 SX800 X700

1.7x Power Zoom Lens

The 1.7x Powered Zoom Lens gives you a diagonal screen size range of 40" when placed 3.9' away and 100" at 9.8' away. With a maximum screen size of 300", REALiS adapts to virtually any room. The incorporation of a dual-sided aspherical lens in the optical array suppresses distortion and keeps peripheral image distortion to an absolute minimum. The result is enhanced resolution for accurate reproduction of highly detailed images.

WUX10 Mark II WUX10 Mark II D SX7 SX6
SX80 Mark II SX80 Mark II D SX60 SX800 X700

4:3 ASPECT RATIO						
Projector screen size	40"	80"	100"	150"	200"	300"
Screen width	2'8"	5'4"	6'8"	10'0"	13'4"	20'0"
Projection distance (Wide -Tele)						
SX7, SX6, SX60, X700	3'11" - 6'6"	7'9" - 13'0"	9'9" - 16'2"	14'7" - 24'4"	19'6" - 29'6"	29'2" - 29'6"
SX80 Mark II, SX80 Mark II D, SX800	3'11" - 5'10"	7'11" - 11'8"	9'10" - 14'6"	14'10" - 21'10"	19'9" - 29'1"	29'7" - 29'10"
16:9 ASPECT RATIO						
Projector screen size	40"	80"	100"	150"	200"	300"
Screen width	2'11"	5'10"	7'3"	10'11"	14'6"	N/A
Projection distance (Wide -Tele)						
SX7, SX6, SX60, X700	4'3" - 7'1"	8'6" - 14'1"	10'7" - 17'8"	15'11" - 26'6"	21'3" - 29'6"	N/A
SX80 Mark II, SX80 Mark II D, SX800, WUX10 Mark II, WUX10 Mark II D	4'4" - 6'4"	8'7" - 12'8"	10'9" - 15'10"	16'1" - 23'9"	21'6" - 29'10"	N/A
16:10 ASPECT RATIO						
Projector screen size	40"	80"	100"	150"	200"	300"
Screen width	2'10"	5'8"	7'1"	10'7"	14'2"	21'2"
Projection distance (Wide -Tele)						
WUX10 Mark II, WUX10 Mark II D	4'2" - 6'2"	8'4" - 12'4"	10'6" - 15'5"	15'8" - 23'1"	20'11" - 29'10"	N/A

Proprietary Color Management

Amazing Color Quality and Control

Canon's high-accuracy Color Management System (CMS) ensures accurate color reproduction for an extended color space and compensates for color variances due to lighting differences. The advantage: true HD-quality color even in the toughest conditions.

WUX10 Mark II WUX10 Mark II D SX7 SX6 SX80 Mark II SX80 Mark II D SX60 SX800 X700

Crisp Blacks Enhance Shadow Detail

Precise control prevents the excess leakage of light, producing rich, detailed gradations even in the shadowed portions of images – recreating depth and dimension with stunning drama and realism.

WUX10 Mark II WUX10 Mark II D SX7 SX6 SX80 Mark II SX80 Mark II D SX60 SX800 X700

Adobe RGB Color Match System

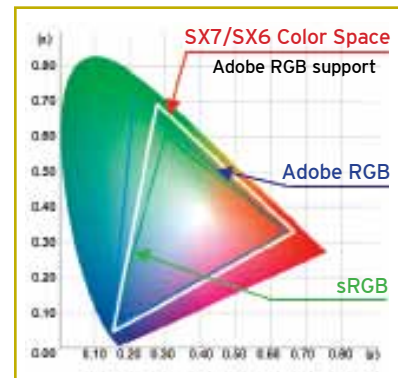

Proprietary color filters incorporated into the AISYS optical system deliver exceptional accuracy and detail in both Adobe RGB and sRGB modes. This is ideal for professional photography, design, publishing, printing and fine art, where color integrity is crucial.

WUX10 Mark II WUX10 Mark II D SX7 SX6 SX80 Mark II SX80 Mark II D SX60 SX800 X700

6-Axis Color Adjustments

A 6-Axis Color Adjustment function meets and exceeds the demands of professionals with demanding color requirements. Both hue and saturation can be adjusted independent of RGB and CMYK color axes.

WUX10 Mark II WUX10 Mark II D SX7 SX6 SX80 Mark II SX80 Mark II D SX60 SX800 X700



A bluer sky



Original

Color Adjusted

More orange in the sunset



Original

Color Adjusted

Versatile Performance

Screen Aspect Modes

Canon REALiS projectors operate brilliantly in both 4:3 aspect ratio and 16:9 aspect ratio. So, no matter which screen you own, you won't need to purchase another.

WUX10 Mark II WUX10 Mark II D SX7 SX6
SX80 Mark II SX80 Mark II D SX60 SX800 X700

AC Projector Lamp

A newly engineered AC lamp boosts the purity of projected reds and greens. Built for extended life as well, it not only ensures more vivid images, it also means a better value.

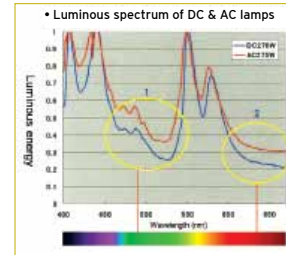

WUX10 Mark II WUX10 Mark II D SX7 SX6
SX80 Mark II SX80 Mark II D SX60 SX800 X700

Image Modes

REALiS projectors allow you to select the image mode that best suits the characteristics of your content. For example, select "Presentation" mode for briefings and conferences or "Adobe RGB" or "sRGB" when color fidelity is essential. The model SX60 even comes equipped with a home cinema filter, making it ideal for this entertainment application. (see below)

WUX10 Mark II WUX10 Mark II D SX7 SX6
SX80 Mark II SX80 Mark II D SX60 SX800 X700

Photo Image Mode

For highly precise color temperature and color level adjustments, Canon has incorporated Photo Image Mode into select REALiS projectors. Ideal for displaying digital camera images, Photo Image Mode provides clearly defined gradations and improved color reproduction.

WUX10 Mark II WUX10 Mark II D SX7 SX6
SX80 Mark II SX80 Mark II D SX60 SX800 X700

DICOM Simulation Mode

DICOM, or Digital Imaging and Communication in Medicine Simulation Mode, allows medical professionals to produce high-resolution images with twenty-one different levels of grayscale gradation for displaying film-like x-rays to large audiences in lecture halls, while also presenting ultra-smooth, lattice-free images.

WUX10 Mark II WUX10 Mark II D SX7 SX6
SX80 Mark II SX80 Mark II D SX60 SX800 X700

Presenter-Friendly Use

Quiet Operation

Why do most projectors make so much noise? It's the cooling system needed to dissipate the considerable heat generated by the unit. On all REALiS models, however, ventilation vents, the cooling fan and the layout of the optical array have all been engineered with noise prevention in mind, resulting in exceptionally quiet operation.

WUX10 Mark II WUX10 Mark II D SX7 SX6
SX80 Mark II SX80 Mark II D SX60 SX800 X700

16:9 Digital Image Shift



Before Shift



Digital Image Shift UP



Digital Image Shift DOWN

16:9 Screen Aspect Mode



Watch 4:3 content on a 16:9 screen



Watch 16:9 content on a 16:9 screen

Dynamic Gamma

When dynamic gamma is "on," gamma is automatically adjusted to optimum values. This feature is vital for projecting rapidly moving images. Each frame is displayed with optimum contrast balance to prevent washed-out whites and blocked-up blacks.

WUX10 Mark II WUX10 Mark II D SX7 SX6
SX80 Mark II SX80 Mark II D SX60 SX800 X700

Image Modes

	WUX10 Mark II WUX10 Mark II D	SX80 Mark II SX80 Mark II D	SX7	SX6	SX60	SX800	X700
Standard							
Presentation							
Movie							
Movie & Photo							
Adobe RGB							
sRGB							
Home Cinema							
Photo Image							
DICOM Simulation							

■ = Standard Prioritizes reproduction of white, closely matching the image characteristics of the original

■ = Presentation Produces a bright, high-contrast display for ease of viewing text and numerical data

■ = Movie Suitable for displaying theatrical content; image quality emphasizes gradation in dark areas

■ = Movie & Photo For display of video and digital camera images; clearly defines gradations and improves color reproduction

■ = Adobe RGB ■ = sRGB Reproduces colors in the appropriate color space for accurate projection of content produced in specific standardized formats

■ = Home Cinema Controls brightness while enhancing contrast to a ratio of 2000:1; for display of theatrical content in pitch-dark rooms

■ = Photo Image provides highly precise color temperature and color level adjustments and clearly defined gradations

■ = DICOM Simulation is used to produce high-resolution images with twenty-one different levels of grayscale gradation

LED Illumination

LEDs on most REALiS models indicate the projector's connection and operation status at a glance. When several image input devices are connected, an LED indicates which image signal is selected as the input. The LED illumination on the operation panel flashes to indicate start-up, end of presentation and other commands.

WUX10 Mark II WUX10 Mark II D SX7 SX6
SX80 Mark II SX80 Mark II D SX60 SX800 X700

Remote Control Convenience

These flexible remote control features enable presenters to drive home a point without ever breaking stride.

WUX10 Mark II WUX10 Mark II D SX7 SX6
SX80 Mark II SX80 Mark II D SX60 SX800 X700

Digital Zoom - enlarges a selected single area of the screen, like specific data in a graph; images can be enlarged up to 12x*.

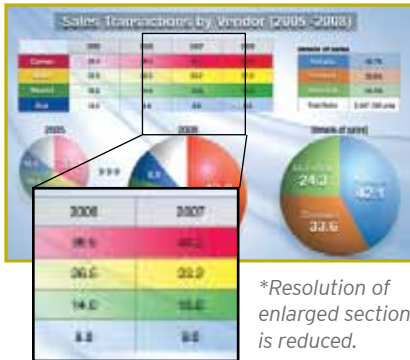

Spot - highlights a portion of the image on the screen; the spotlight can be made larger or smaller, or it can be moved anywhere on the screen.



Freeze - lets you freeze the on-screen display for pauses in the presentation, such as changing PC connections or checking the subsequent image file.

Auto Setup

These smart features make preparing for a presentation quick and easy. Just press the Auto Setup button, and within seconds your input source is connected, distortion is corrected, focus is sharpened and color is balanced.

*The SX800 Auto-Set-up feature does not include Auto Focus and Auto Screen Color

WUX10 Mark II WUX10 Mark II D SX7 SX6
SX80 Mark II SX80 Mark II D SX60 SX800 X700

Auto Keystone - automatically calculates the angle of the projector and corrects for image distortion. Vertical (+/- 20°).



Auto Screen Color - automatically adjusts the color balance according to the projection surface's color, such as a green chalkboard.

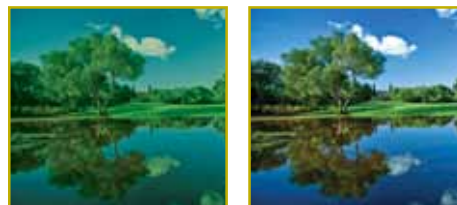

Auto Input - automatically detects and identifies the image signal from the input terminal and selects it for display.

Auto Focus - automatically measures the distance to the screen using an infrared sensor, and adjusts the focus in as little as one second.



Direct Power On

All models can be switched on and off from a central control terminal without having to press the buttons on the unit. This permits

remote operation when the unit is mounted overhead. When the Direct Power setting is "on," and power is introduced, the projector starts up automatically and is ready to display in about 20 seconds.

WUX10 Mark II WUX10 Mark II D SX7 SX6
SX80 Mark II SX80 Mark II D SX60 SX800 X700

Guide Functions

All REALiS models display guide messages in an on-screen window, providing feedback on invalid operations and setup tips.

WUX10 Mark II WUX10 Mark II D SX7 SX6
SX80 Mark II SX80 Mark II D SX60 SX800 X700

Off and Go

All REALiS models are equipped with an internal charging system to run the fan. This makes it possible to unplug the projector and pack up and go immediately after using it, while the unit continues to cool down.

WUX10 Mark II WUX10 Mark II D SX7 SX6
SX80 Mark II SX80 Mark II D SX60 SX800 X700



Before Auto Focus



After Auto Focus



Guide functions display

Convenient. Connectable. Compatible.

REALIS MULTIMEDIA PROJECTORS ARE NOT ONLY EASY FOR PRESENTERS TO USE, BUT ALSO FOR ORGANIZATIONS TO INSTALL, NETWORK AND MAINTAIN. OUR TECHNOLOGY IS ENGINEERED FOR SEAMLESS INTEGRATION WITH A VARIETY OF INFORMATION TECHNOLOGY, NETWORK MANAGEMENT AND AUDIO/VISUAL ENVIRONMENTS. IN A PHRASE, IT'S BUILT TO FIT IN.

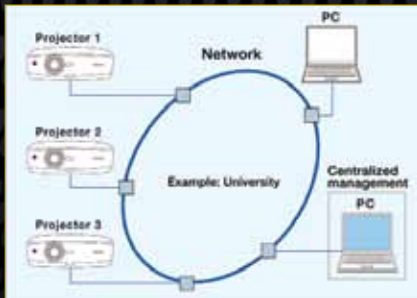

Flexible Compatibility

REALIS Multimedia Projectors are compatible with a variety of image signals, including HDTV.

- 1 Digital RGB Input/
Analog RGB Output (DVI-I)
- 2 HDMI In
- 3 Analog RGB Input
- 4 Component Input
- 5 Monitor Output
- 6 USB Port
- 7 S-Video Terminal
- 8 Video Input
- 9 Stereo Audio Input
- 10 Stereo Audio Output
- 11 RS-232C/Controller
- 12 Network

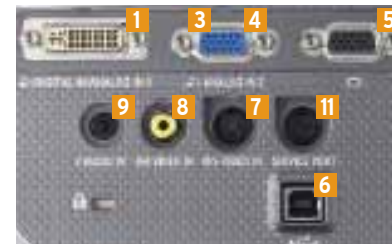
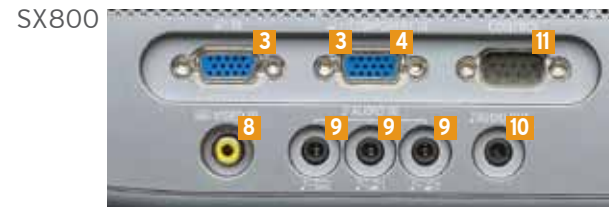

SX6 / SX60

SX7 / X700

Network Management

With the optional network adapter, you can operate the projector from a networked PC. Multiple projectors can also be managed remotely this way. This feature makes it possible to operate ceiling-mounted units or other remote installations from a single PC screen. The WUX10 Mark II and the SX80 Mark II come with a network port built in.

WUX10 Mark II WUX10 Mark II D SX7 SX6
SX80 Mark II SX80 Mark II D SX60 SX800 X700

Audio Input & Output

Audio input source will switch automatically to match the image signal source. Audio output terminals permit connection to external audio devices, making it easy to control sound levels from the projector's remote control unit.

WUX10 Mark II WUX10 Mark II D SX7 SX6
SX80 Mark II SX80 Mark II D SX60 SX800 X700

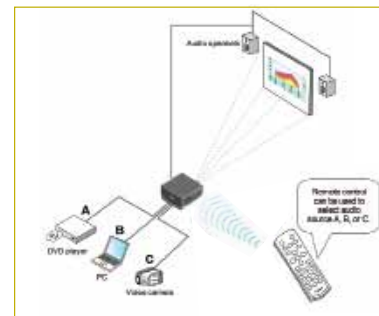

PC-Free Presentations

Need to share media not resident on a PC? No problem with our convenient built-in interfaces. Connect a USB memory stick directly into the projector, connect a PictBridge-compatible digital camera via USB cable or use the HDMI™ terminal for instant display of HD video.

WUX10 Mark II WUX10 Mark II D SX7 SX6
SX80 Mark II SX80 Mark II D SX60 SX800 X700



Kit Contents

REALiS projectors come with everything you need to begin presenting right out of the box.

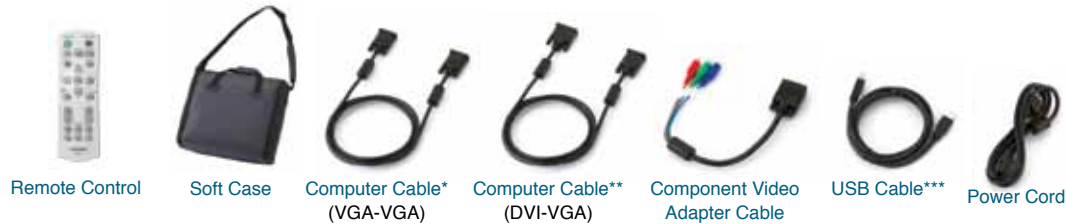

*Only included with the SX800. **Not included with the SX800.

***Not included with the WUX10 Mark II, WUX10 Mark II D, SX80 Mark II, SX80 Mark II D, or SX800.

Optional Accessories

To increase the performance value of your REALiS projector, add these smart accessories.

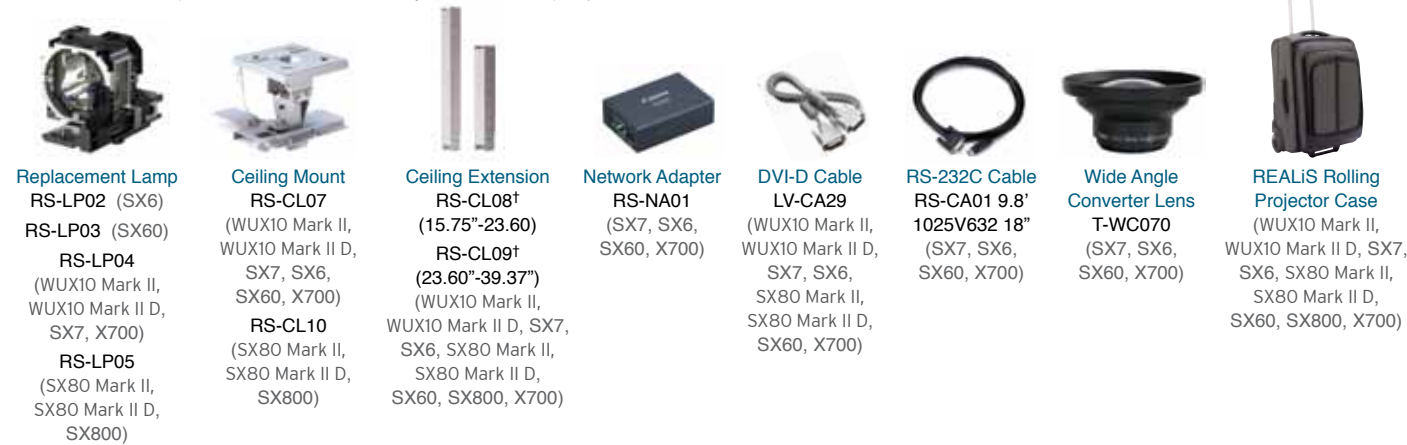

Replacement Lamp
RS-LP02 (SX6)
RS-LP03 (SX60)
RS-LP04
 (WUX10 Mark II,
 WUX10 Mark II D,
 SX7, X700)
RS-LP05
 (SX80 Mark II,
 SX80 Mark II D,
 SX800)

Ceiling Mount
RS-CL07
 (WUX10 Mark II,
 WUX10 Mark II D,
 SX7, SX6,
 SX60, X700)
RS-CL10
 (SX80 Mark II,
 SX80 Mark II D,
 SX800)

Ceiling Extension
RS-CL08†
(15.75"-23.60)
RS-CL09†
(23.60"-39.37")
 (WUX10 Mark II,
 WUX10 Mark II D, SX7,
 SX6, SX80 Mark II,
 SX80 Mark II D,
 SX60, SX800, X700)

Network Adapter
RS-NA01
 (SX7, SX6,
 SX60, X700)

DVI-D Cable
LV-CA29
 (WUX10 Mark II,
 WUX10 Mark II D,
 SX7, SX6,
 SX80 Mark II,
 SX80 Mark II D,
 SX60, X700)

RS-232C Cable
RS-CA01 9.8'
1025V632 18"
 (SX7, SX6,
 SX60, X700)

**Wide Angle
 Converter Lens**
T-WC070
 (SX7, SX6,
 SX60, X700)

**REALiS Rolling
 Projector Case**
 (WUX10 Mark II,
 WUX10 Mark II D, SX7,
 SX6, SX80 Mark II,
 SX80 Mark II D,
 SX60, SX800, X700)

†Compatible with the RS-CL07 and RS-CL10.

Customer Service

How do you make what's already better *best* in its class? You provide unprecedented customer support. Like our "Triple P" Program.



"Triple P" Program

Canon's Projector Protection Program, also known as "Triple P," is a service program that provides a loaner projector of equal or greater quality in the event that your projector needs to be repaired.

- Free to any buyer within the 3-year new product limited warranty
- Canon Customer Support Center toll-free hotline: 1-800-828-4040
- Customer Service Hours: 8 a.m. to midnight, Monday - Friday and 10 a.m. to 8 p.m., Saturday EST
- For next business day delivery of loaner projector(s), a Customer Activation Form must be received by Canon Customer Support Center by 3 p.m. EST (Monday - Friday)
- Customer must provide a valid credit card as security for the loaner unit
- Delivery not available on Saturday and Sunday
- Program available for products purchased and utilized in the U.S.A. only
- Applies to Canon Multimedia Projectors only
- Loaner unit based on availability
- Program subject to change at any time without any given notice

Specifications and availability are subject to change without notice. Weight and dimensions are approximate. All images and effects are simulated. Canon, image*ANYWARE*, and REALiS are registered trademarks of Canon Inc. in the United States and may also be registered trademarks in other countries. Microsoft and Windows are either registered trademarks or trademarks of the Microsoft Corporation in the United States and/or other countries. HDMI, the HDMI logo and High Definition Multimedia Interface are trademarks or registered trademarks of HDMI Licensing LLC. Other names and products not mentioned above may be registered trademarks or trademarks of their respective companies. Warning: Unauthorized recording of copyrighted materials may infringe on the rights of copyright owners and be contrary to copyright laws.

Make it real.
 Make it REALiS.

FROM ANY DIRECTION AND FROM ALL ANGLES, CANON HAS PROJECTION EXCELLENCE COVERED. THERE'S NO MORE COMPELLING EXAMPLE OF THIS THAN OUR TOP-TIER LINEUP OF REALiS LCOS MULTIMEDIA PROJECTORS. IF YOU'RE LOOKING FOR OUTSTANDING PRESENTATION TECHNOLOGY, TURN YOUR ATTENTION TO THE LEADER IN THE FIELD. MAKE IT REALiS. MAKE IT CANON.

Canon
imageANYWARE

Product Specifications

FEATURES	NEW!		NEW!				
	WUX10 Mark II WUX10 Mark II D	SX7	SX6	SX80 Mark II SX80 Mark II D	SX60	SX800	X700
Brightness	3200 Lumens	4000 Lumens	3500 Lumens	3000 Lumens	2500 Lumens	3000 Lumens	4000 Lumens
Contrast Ratio		1000:1		900:1	1000:1/2000:1 in Home Cinema mode	900:1	1000:1
Imaging Technology		0.7" LCOS x 3		0.55" LCOS x 3	0.7" LCOS x 3	0.55" LCOS x 3	0.7" LCOS x 3
DICOM Simulation	Mark II D only	N/A		Mark II D only		N/A	
Photo Mode	YES	N/A		YES		N/A	
Native Resolution	1920 x 1200 Pixels			1400 x 1050 Pixels			1024 x 768 Pixels
Max. Resolution Supported	1920 x 1200			1600 x 1200 Max			
Weight	10.9 lbs.	10.6 lbs.	10.4 lbs.	11.5 lbs.	10.1 lbs.	11.0 lbs.	10.6 lbs.
Dimensions (WxDxH)	11.2" x 13.2" x 4.5"	10.5" x 13.2" x 4.5"		13.0" x 13.4" x 4.8"	10.5" x 13.2" x 4.5"	13.0" x 13.4" x 4.8"	10.5" x 13.2" x 4.5"
Lens Offset	10:0, Fixed	9:1, Fixed		10:0, Fixed	9:1, Fixed	10:0, Fixed	9:1, Fixed
Zoom Lens	1.5x Powered 12x Digital	1.7x Powered 12x Digital		1.5x Powered 12x Digital	1.7x Powered 12x Digital	1.5x Powered 12x Digital	1.7x Powered 12x Digital
Focus				Powered (Auto/Manual)		Powered (Manual)	Powered (Auto/Manual)
Screen Size				40" - 300"			
Projection Distance	3.9 - 29.9 ft (1.2 - 9.1 m)	3.9 - 29.5 ft (1.2 - 9.0 m)		3.9 - 29.9 ft (1.2 - 9.1 m)	3.9 - 29.5 ft (1.2 - 9.0 m)	3.9 - 29.9 ft (1.2 - 9.1 m)	3.9 - 29.5 ft (1.2 - 9.0 m)
Throw Ratio (D:W)	1.48 - 2.18:1	1.46 - 2.43:1		1.48 - 2.18:1	1.46 - 2.43:1	1.48 - 2.18:1	1.46 - 2.43:1
Uniformity				88%			
Digital Keystone Correction	+20° vertical (Auto/Manual)	+20° vertical (Auto/Manual), +/-20° horizontal (Manual)		+20° vertical (Auto/Manual)	+20° vertical (Auto/Manual), +/-20° horizontal (Manual)	+20° vertical (Auto/Manual)	+20° vertical (Auto/Manual), +/-20° horizontal (Manual)
Computer Inputs/Outputs		Digital PC Input (DVI-I) [†] , Analog PC Input (D-sub 15pin and/or DVI-I) ^{††} , Analog PC Output (D-sub 15pin) ^{†††}					
Scanning Frequency	H:15 ~ 75kHz, V:50 ~ 85Hz, Dot clock: 170MHz	H:15 ~ 100kHz, V:50 ~ 100Hz, Dot clock: 170MHz		H:15 ~ 75kHz, V:50 ~ 85Hz, Dot clock: 170MHz	H:15 ~ 100kHz, V:50 ~ 100Hz, Dot clock: 170MHz	H:15 ~ 75kHz, V:50 ~ 85Hz, Dot clock: 170MHz	H:15 ~ 100kHz, V:50 ~ 100Hz, Dot clock: 170MHz
Video Inputs	HDMI, Component*, Composite	DVI-I, Component*, S-Video, Composite		HDMI, Component*, Composite	DVI-I, Component*, S-Video, Composite	Component*, Composite	DVI-I, Component*, S-Video, Composite
Video Support	1080p / 1080i / 1035i / 720p / 576p / 480p / 576i / 480i	1080i / 1035i / 720p / 575p / 480p / 575i / 480i		1080p / 1080i / 1035i / 720p / 576p / 480p / 576i / 480i	1080i / 1035i / 720p / 575p / 575i / 480p / 480i	1080p / 1080i / 1035i / 720p / 576p / 576i / 480p / 480i	1080i / 1035i / 720p / 575p / 575i / 480p / 480i
Audio Input/Output		Stereo audio input x 3, Stereo audio output x 1	Stereo audio input x 1	Stereo audio input x 3, Stereo audio output x 1	Stereo audio input x 1		Stereo audio input x 3, Stereo audio output x 1
Mouse Control/PictBridge	N/A	USB		N/A	USB	N/A	USB
Serial Control	D-Sub 9	Mini DIN 8 pin		D-Sub 9 pin	Mini DIN 8 pin	D-Sub 9 pin	Mini DIN 8 pin
Network	Yes, RJ-45	Optional Adapter		Yes, RJ-45	Optional Adapter	N/A	Optional Adapter
Lamp Type		275W NSH (AC)	270W NSH (DC)	230W NSH (AC)	180W NSH (DC)	230W NSH (AC)	275W NSH (AC)
Lamp Life (Normal/Quiet)		2000/3000 Hours	1500/2000 Hours	2000/2500 Hours	2500/4000 Hours	2000/2500 Hours	2000/3000 Hours
Noise Level (Normal/Quiet)		36/32dB	35/31dB		30/27dB		35/31dB
Power Voltage		AC 100 - 240V, 50/60Hz					
Warranty		3 years parts and labor, 120-day lamp warranty					

Canon
image*ANYWARE*

1-800-OK-CANON
www.usa.canon.com/projectors

Canon U.S.A., Inc.
One Canon Plaza
Lake Success, NY 11042 U.S.A.

Canon Canada Inc.
6390 Dixie Road
Mississauga, Ontario L5T 1P7 Canada

Canon Latin America
703 Waterford Way, Suite 400
Miami, FL 33126 U.S.A.

Canon Mexicana, S. de R.L. de C.V.
Blvd. Manuel Ávila Camacho
No. 13B, Piso 17
Col. Lomas de Chapultepec
C.P. 11000 México, D.F. México

©2009 CANON U.S.A., INC.
PRINTED IN U.S.A.

0138W849 10/09

[†] Not available on the SX800 ^{††} DVI-I replaced by the D-sub 15pin on the SX800

^{†††} Not available on the WUX10 Mark II and the SX800 * Component (5BNC) using analog PC input 2.

Errors and omissions excepted. Weight and dimensions are approximate. Specifications subject to change without notice.