

16X

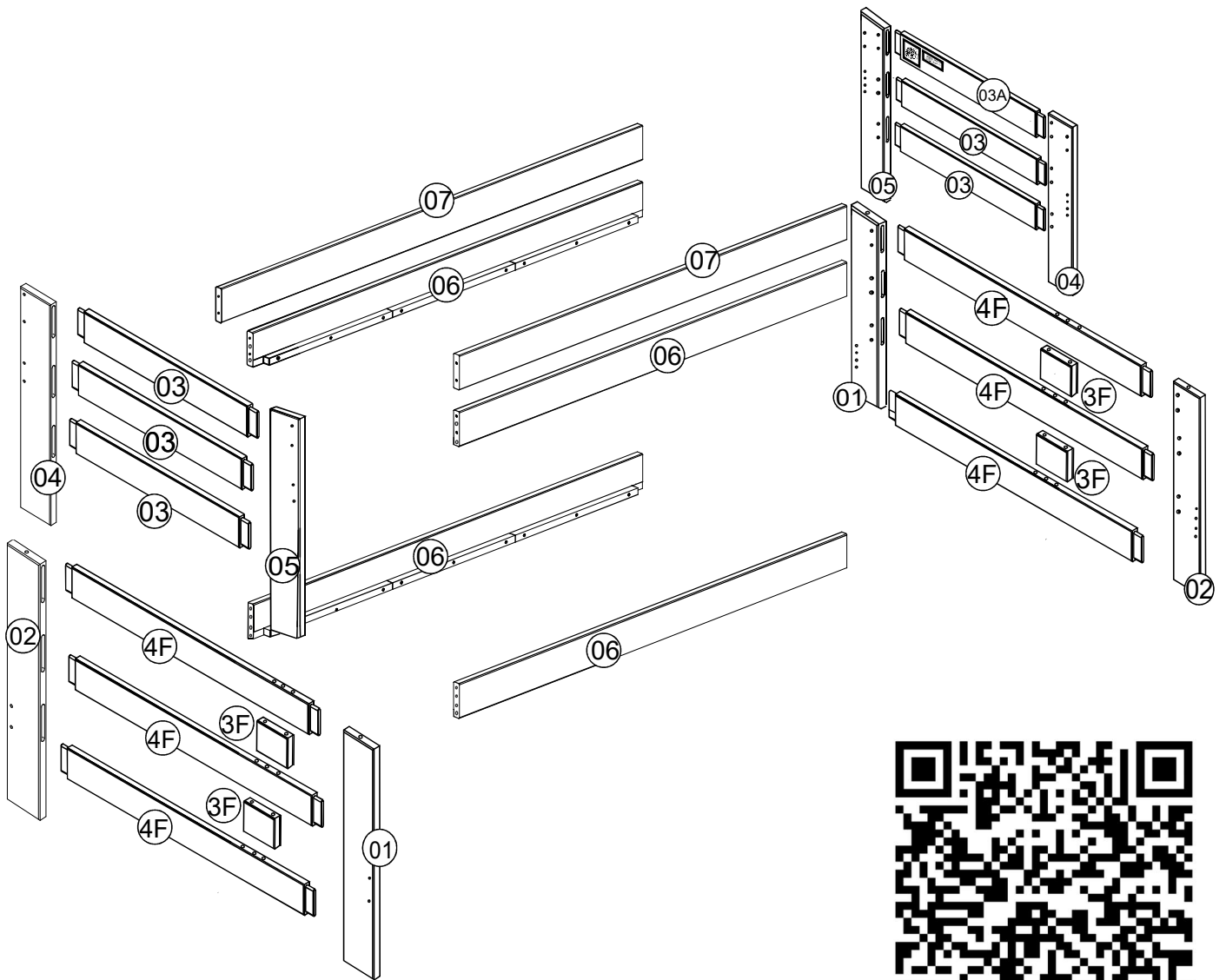

Scan Here

for Assembly Animation



OPEN YOUR
CAMERA



AIM IT AT THE
QR CODE



TAP THE
BANNER

READ THESE INSTRUCTIONS CAREFULLY BEFORE ATTEMPTING TO ASSEMBLE THIS BED

⚠ WARNING ⚠

To help prevent serious or fatal injuries from entrapment or falls:

- * Read & follow the information on the WARNING shown on the end structure of the upper bunk or on the carton.
- * **DO NOT** remove the warning label from the bed.
- * Keep these instructions for future reference.
- * Use only a mattress meeting the following specifications on all upper and lower bunks.

Bed Type	Width	Length		Bed Type	Width	Length
Standard Twin	37½"-38½"	74"-75"		XL Twin	37½"-38½"	79"-80"
Standard Full	52½"-53½"	74"-75"		XL Full	52½"-53½"	79"-80"

- * Total thickness of both mattress and foundation combined **MUST NOT EXCEED 6"** for all top and bottom bunks.
 - * Surface of mattress must be at least 5 inches (127mm) below the upper edge of guardrails.
 - * The **MAXIMUM** weight capacity for the upper bunk is not to exceed 225 lbs.
 - * **DO NOT** allow children under 6 years of age to use upper bunk.
 - * Periodically check and ensure that the guardrails, ladder, handle and other components are in their proper position, free from damage and that all connectors are tightened and secure.
 - * **DO NOT** allow horseplay, rough playing or jumping on the beds and do not allow playing or hiding under the beds.
 - * Always use the ladder for entering or leaving the upper bunk.
 - * **DO NOT** use substitute parts. Contact the manufacturer or dealer for replacement parts.
 - * Use of a nightlight may provide added safety precaution for a person using the upper bunk.
 - * Always use the guardrails on both sides of the upper bunk.
 - * If the bunk bed will be placed next to a wall, the guardrails that run the full length of the bed should be placed against the wall to prevent entrapment between the bed and the wall.
 - * The use of water or sleep flotation mattresses is prohibited.
 - * No more than one person is allowed on the upper bunk at a time.
- STRANGULATION HAZARD:** Never attach or hang objects to any part of the bed that are not designed for use with the bed. Objects such as hangers, hooks, belts, bags, ropes, string, etc. should not be used on or around the bunk bed.

DO NOT REMOVE THIS LABEL

SLAT KIT, BUNKIE BOARD, or BUNKIE MATTRESS MUST BE USED WITH THIS BUNK BED
MAXIMUM WEIGHT LIMIT IS 225 LBS.

REPLACEMENT PARTS

Replacement parts, including additional guardrails, may be obtained from:

Pine Crafter Furniture
PO Box 1100
Haleyville, AL 35565
P: 205.486.2153

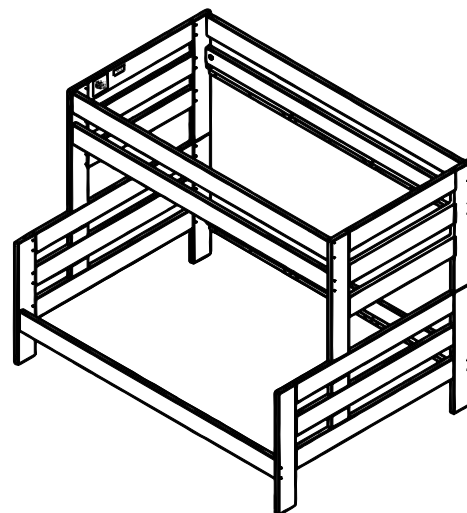

16X

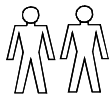

60 min

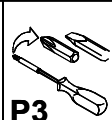

P3

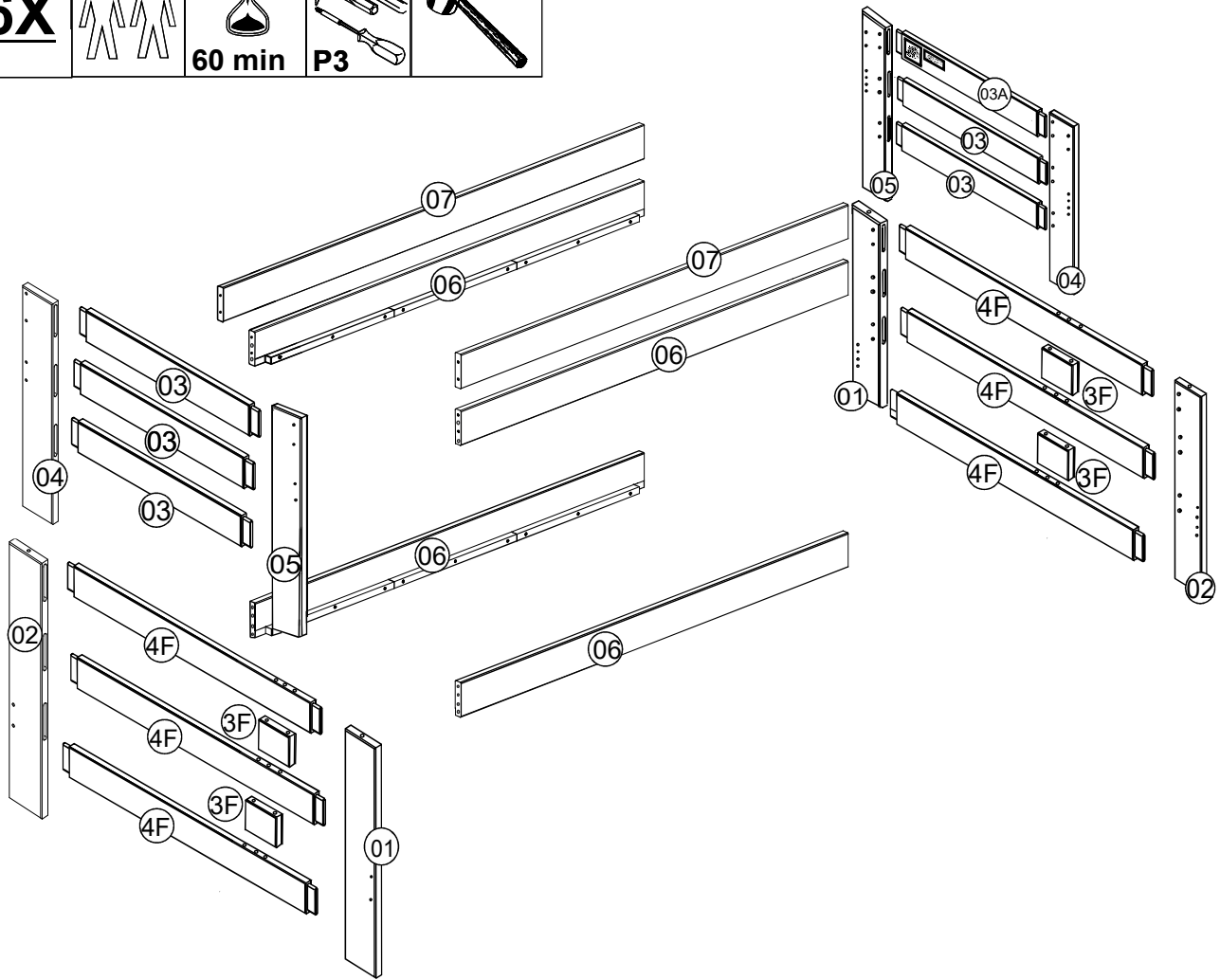

A

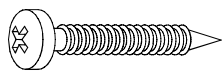

BLACK 4,5X20

B



10X40

C



BLACK 1/4X70

D



SILVER

E

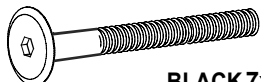

BLACK 7x70

F

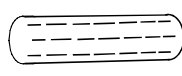

METAL 9,5X85

G



GOLD 4,0X22

H

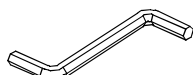

SILVER

I



TOP BED WIRE SILVER

03

J

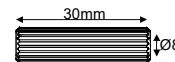

8X30

K

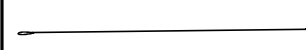

BOTTOM BED WIRE SILVER

03

01

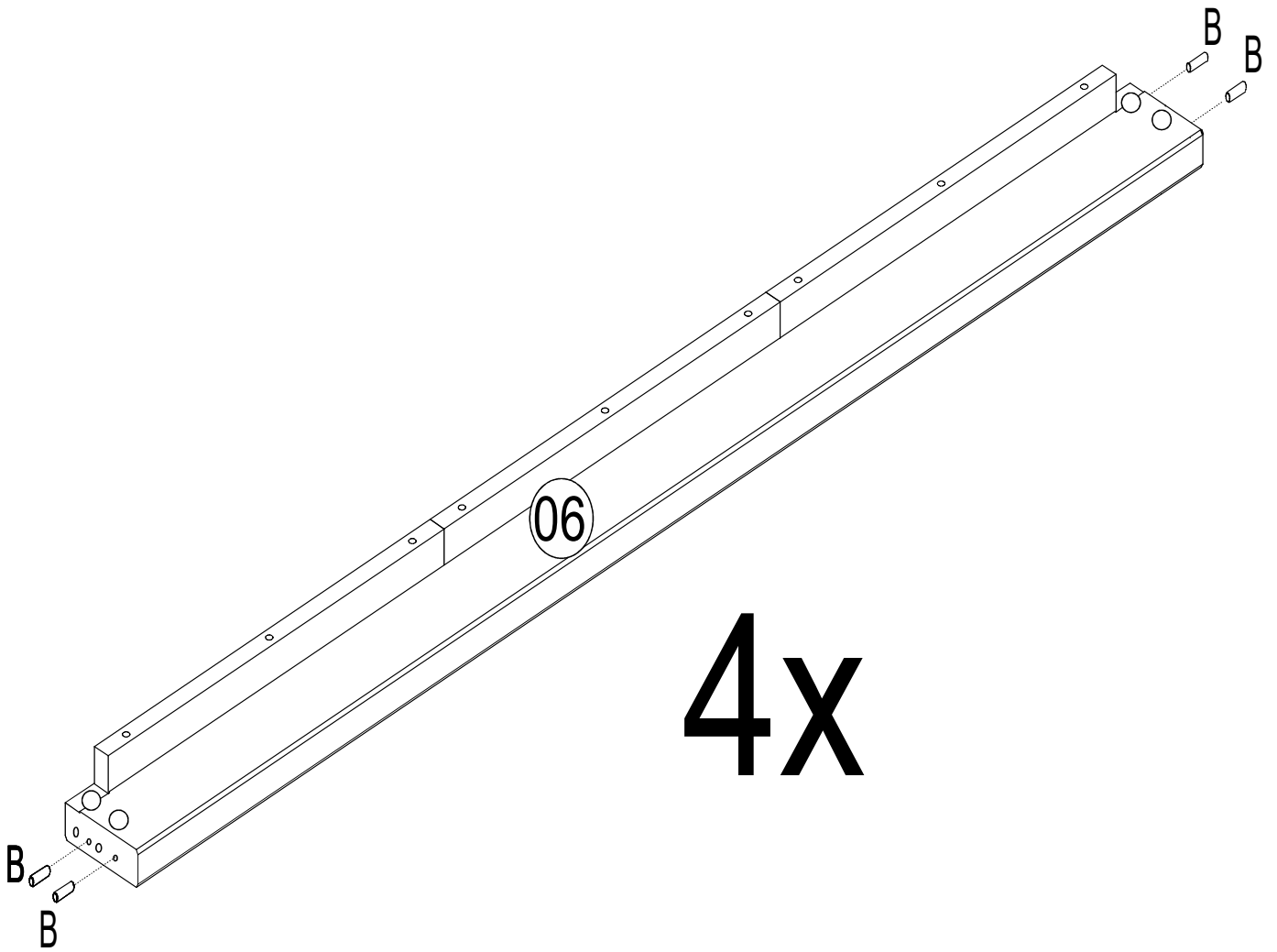

4x

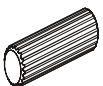

B

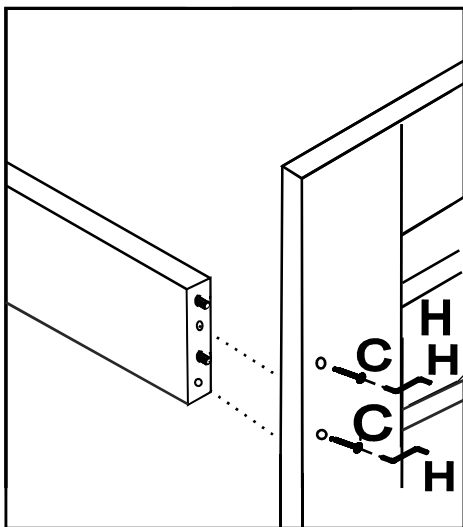
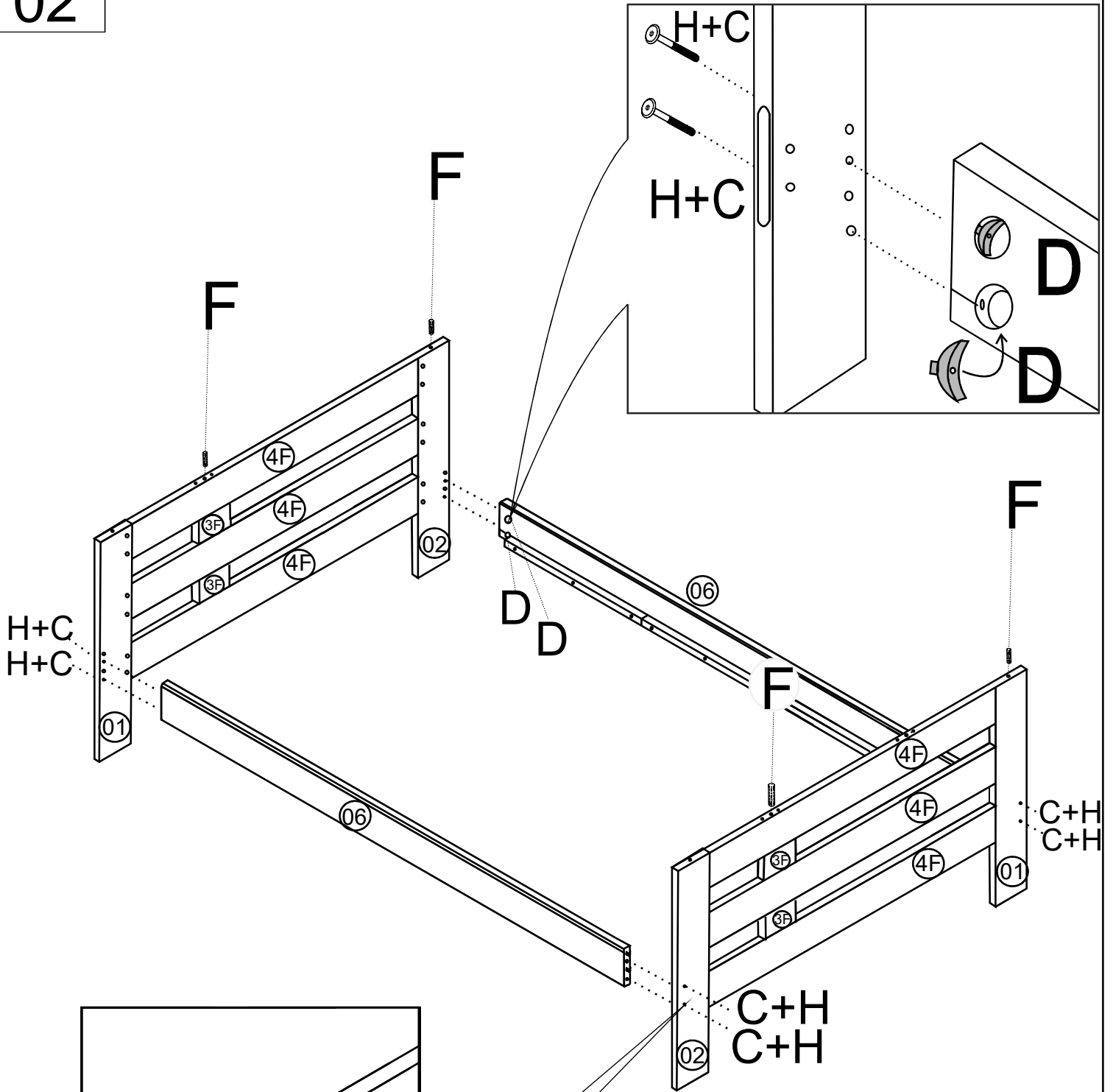

10x40

16

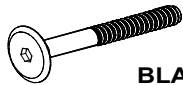

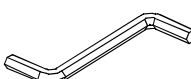

C	 BLACK 1/4X70	08
D	 SILVER	08
F	 METAL 9,52X85	04
H	 SILVER	02

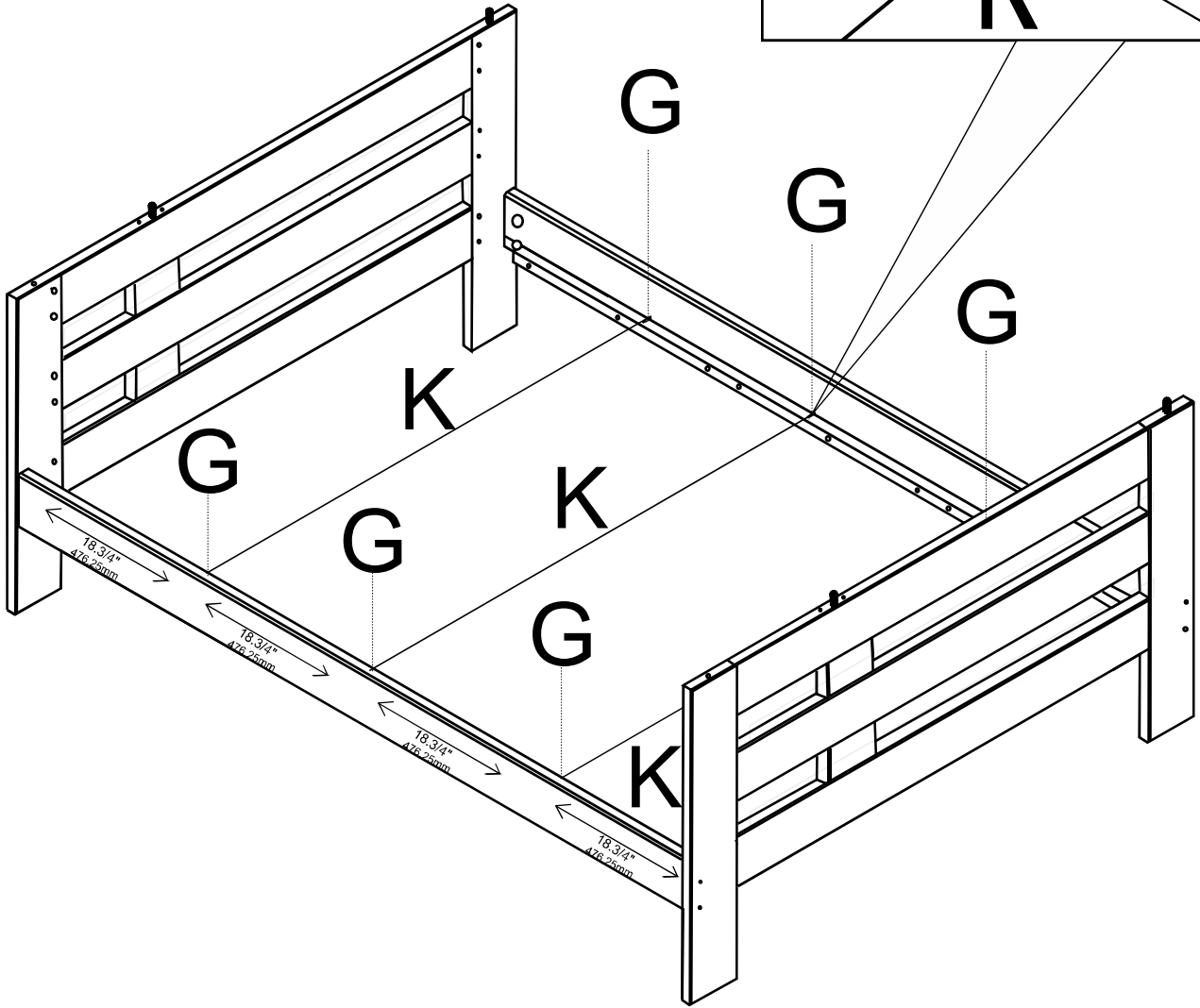
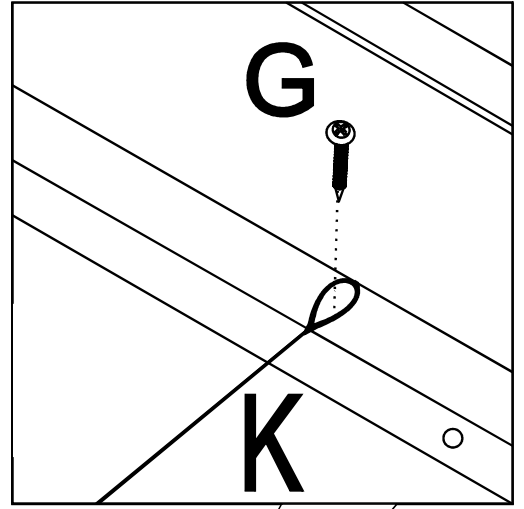

03

Bed wires are not to be used as a foundation.
Their purpose is to keep the mattress from
falling through bed frame.
A separate bunkie board, slat kit, plywood or
innerspring mattress must be used for a foundation.

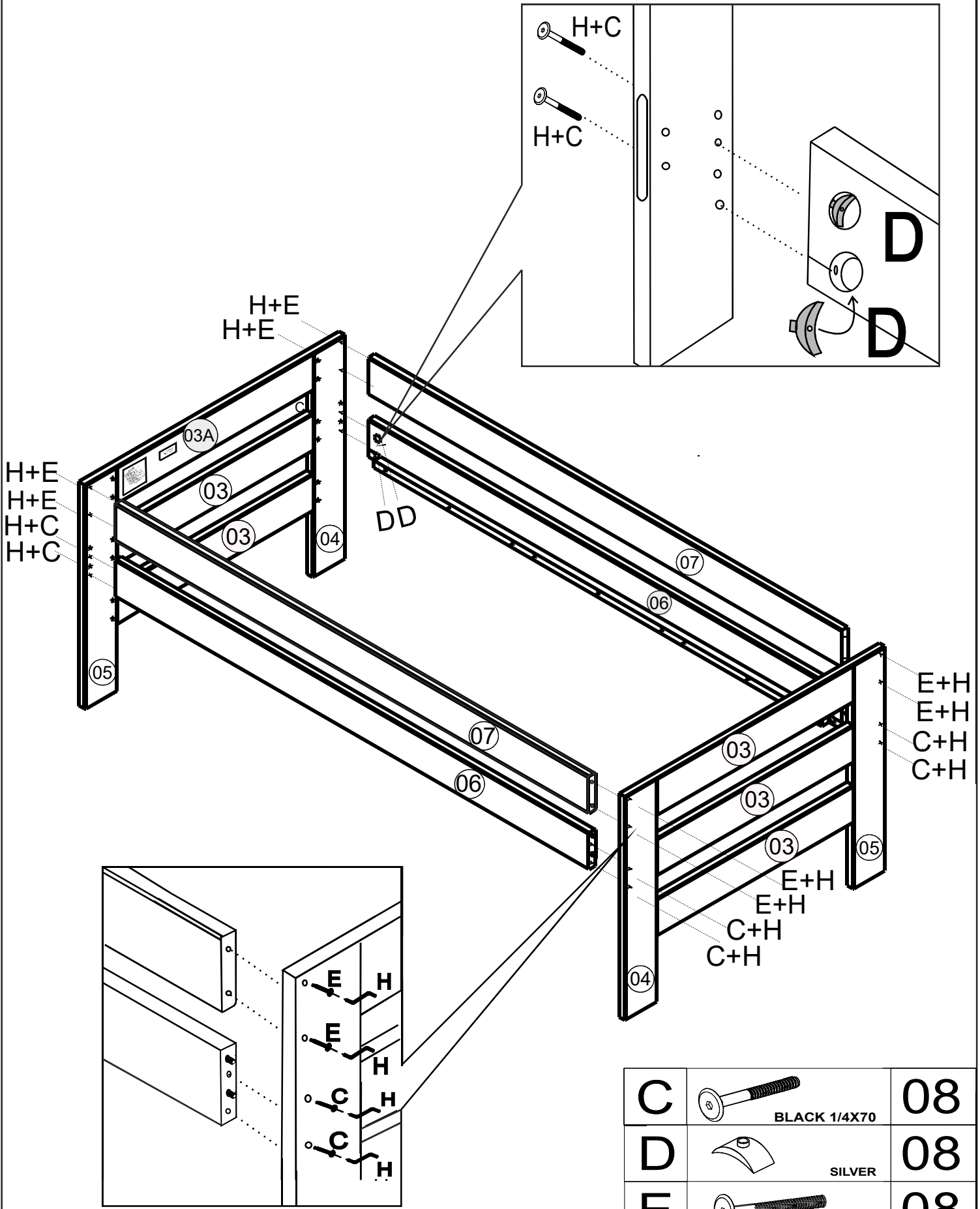

G	 GOLD 4,0X22	06
K	 BOTTOM BED WIRE SILVER	03

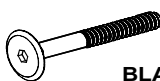

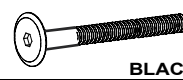
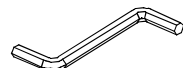

C	 BLACK 1/4X70	08
D	 SILVER	08
E	 BLACK 7,0X70	08
H	 SILVER	02

05

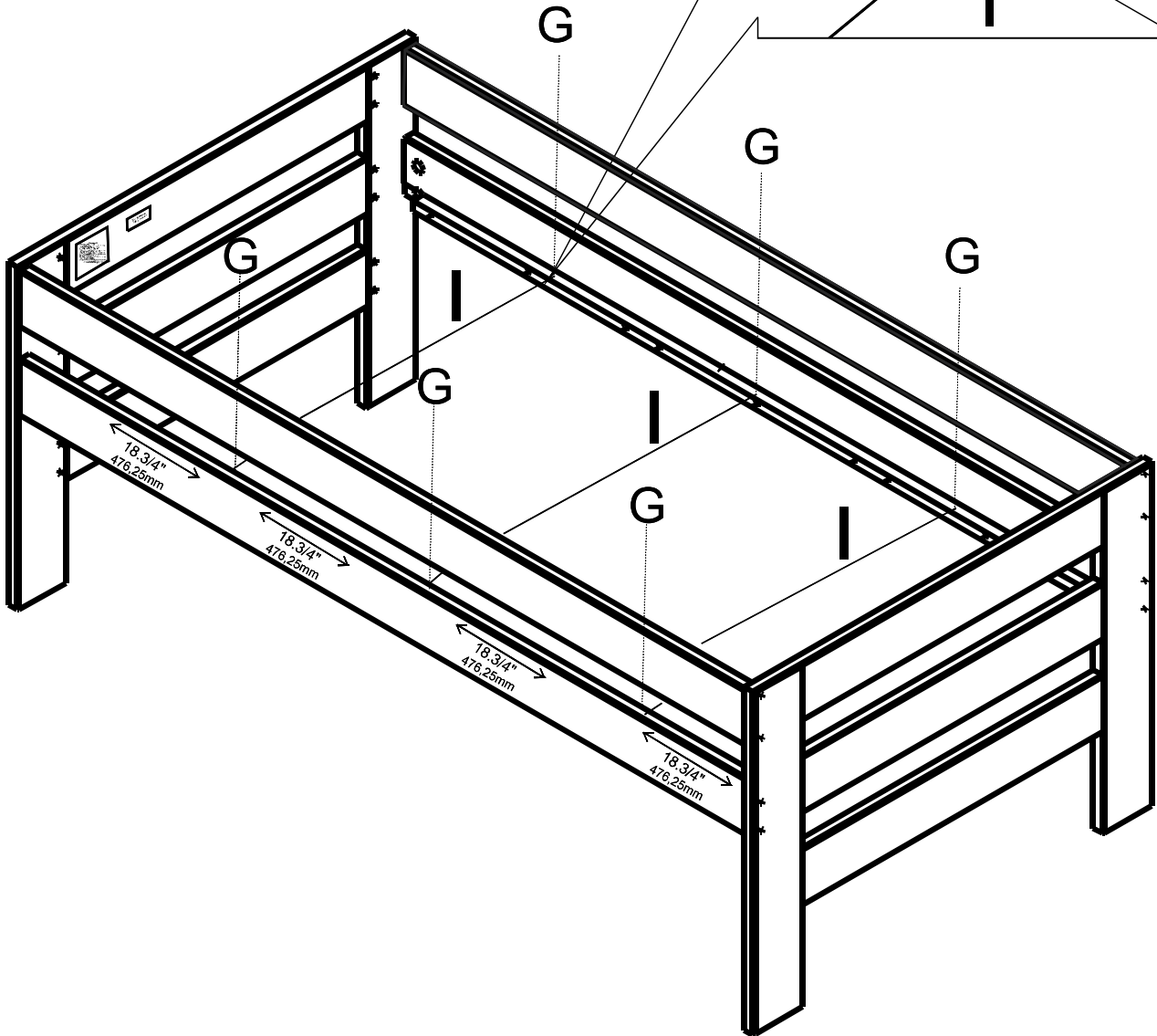
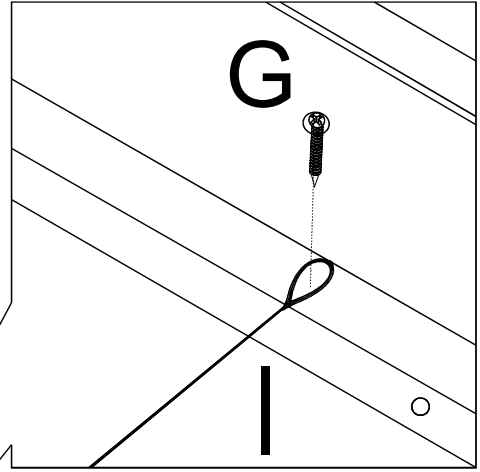
Bed wires are not to be used as a foundation.
Their purpose is to keep the mattress from
falling through bed frame.
A separate bunkie board, slat kit, plywood or
innerspring mattress must be used for a foundation.

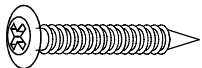

G	 GOLD 4,5x20	06
I	 TOP BED WIRE SILVER	03

06

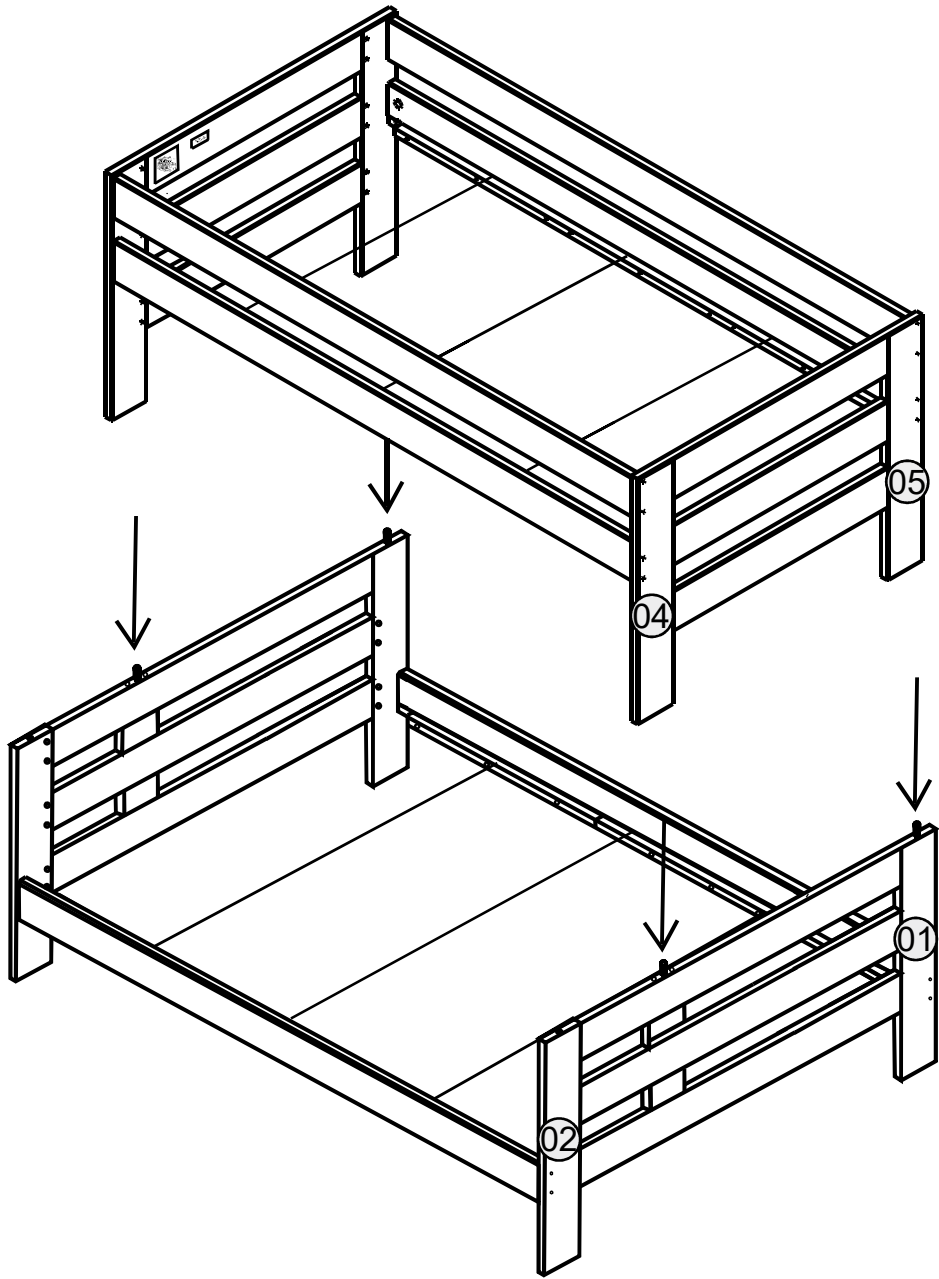

07

